

Model: 911U

UL Listed Cast Iron Flanged End Y Strainers for Firelines Sizes: 2½" - 12" (60 - 300mm)

Pressure/Temperature-Non-Shock		
Model	Material	Rating CWP
911U	Cast Iron	175psi @ 150°F 12 bar @ 66°C 125psi @ 406°F

Strainers provide economical protection for costly pumps, meters, valves, and other similar mechanical equipment by straining foreign matter from the connected piping system.

Typical Service

These strainers are UL approved and are used to prevent clogging in fire service systems such as automatic sprinkler systems and various spray systems.

911U

Class 125

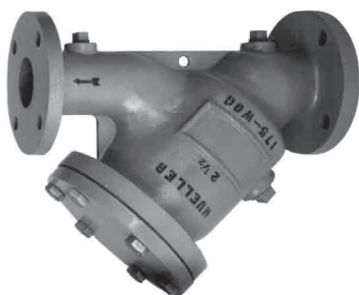

Model 911U

Features

- Extra large baskets have an Open Area Ratio of at least 7 to 1. AWWA a minimum requirement is 4 to 1 Ratio
- Extra large capacity baskets equal very low pressure drop and long intervals between cleaning and servicing, essential in this service.
- NPT tapped blow-off connections are available on request.

Pressure Drop

SIZE	PRESSURE DROP @ 15 FT/SEC
2½"	2.31
3"	3.27
4"	3.18
5"	3.62
6"	3.59
8"	3.08
10"	3.29
12"	2.79

Screen

MODEL	SIZES	STANDARD (WATER)	
		MATERIAL	OPENING
911U	2½" - 12"	304SS	.250 perf

Material

	911U
Body	Cast Iron ASTM A126 Grade B
Cover	Steel ASTM A515 Grade 70
Gasket	Compressed Fiber

Job Name _____

Contractor _____

Job Location _____

Approval _____

Engineer _____

Contractor's P.O. No. _____

Approval _____

Representative _____

Dimensions and Weights

SIZE		DIMENSIONS						WEIGHT	
		A		B		C			
in.	mm	in.	mm	in.	mm	in.	mm	lbs.	kgs.
2½	60	14	356	10¼	200	14	356	60	27
3	80	14¾	375	10¾	208	15	381	65	29
4	100	17½	445	12 ⁹ / ₁₆	318	18	457	125	56
5	125	19¾	502	14½	276	20½	521	172	78
6	150	21 ⁵ / ₈	549	15 ⁷ / ₈	298	22	559	210	95
8	200	26	660	21½	398	30½	774.7	360	163
10	250	31	787	24¾	467	35½	902	610	277
12	300	37¼	946	29½	552	42½	1080	1045	475

Apply for Certified Drawings

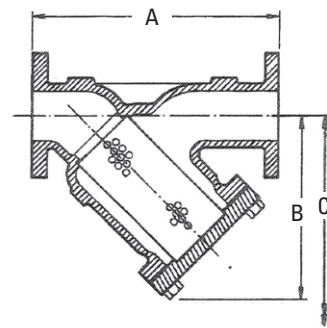

Model 911U

Mueller Steam Specialty product specifications in U.S. customary units and metric are approximate and are provided for reference only. For precise measurements, please contact Mueller Steam Specialty Technical Service. Mueller Steam Specialty reserves the right to change or modify product design, construction, specifications, or materials without prior notice and without incurring any obligation to make such changes and modifications on Mueller Steam Specialty products previously or subsequently sold.



A Watts Water Technologies Company

ES-MS-911U 1020



USA: St. Pauls, NC • Tel. 1-800-334-6259 • Fax 1-800-421-6772 • www.muellersteam.com

© 2010 Mueller Steam Specialty