

Models: 792FB, 794FB

Ball-Plex™ Bronze Flanged End Duplex Strainers Sizes: 1" - 6" (25 - 150mm)

Pressure / Temperature - Non-Shock		
Model	Material	Rating
792FB	Bronze	225psi @ -20°F to 150°F 15.51 bar @ 65.56°C 195psi @ 250°F 13.44 bar @ 121.11°C
794FB	Bronze	500psi @ -20°F to 150°F 34.47 bar @ 65.56°C 425psi @ 250°F 29.30 bar @ 121.11°C

Max. temp. can be limited by gasket and seat material. Consult factory.

792FB **Class 150**
794FB **Class 300**



Models 792FB, 794FB

Strainers provide economical protection for costly pumps, meters, valves, and other similar mechanical equipment by straining foreign matter from the connected piping system. Installation of a strainer before mechanical equipment can ensure trouble free service and avoid costly shutdowns for repair or replacement of equipment damaged by foreign matter. The size of the perforation or mesh in the basket screen will determine the smallest particles captured. See Strainer information section of the Mueller Steam Specialty Engineering binder for detailed information including sizes and materials available.

Typical Service

- Duplex Strainers are designed for use in fluid handling systems where the flow cannot be shutdown for basket cleaning.
- Typical services include cooling water, compressors, condensers, fire lines, fuel lines, lubrication systems, salt and fresh water systems, chemical process systems, pump suction service, and more.
- Consider strainer body and screen material as well as gasket and seat materials for suitability for particular service.

Features

- Ball-Plex™ Duplex Strainers use 3-way balls as the diverter valves
- Balls are 316SS for corrosion resistance, strength, and resistance to build-up of solids on the balls' surfaces.
- PTFE seats provide bubble-tight sealing, superior to metal seats in other designs. This eliminates potentially dangerous leakage into the chamber being cleaned.
- Two part body casting allows true and easy in-line service
- After removal of the cover and basket, all working parts are easily accessible even with the unit in line.
- The handle covers the pressurized chamber. This prevents accidental opening of the pressurized chamber, and allows easy access to the chamber to be cleaned.

Baskets

- Large Open Area Ratios ensure minimum pressure drop across the unit.
- See Technical Data Section of the Mueller Steam Specialty Engineering binder for Pressure Drop Charts.

MODEL	SIZES	STANDARD (WATER)	
		MATERIAL	OPENING
792FB, 794FB	1" - 4"	304SS	.062 perf
792FB, 794FB	5" - 6"	304SS	.125 perf

Job Name _____
 Job Location _____
 Engineer _____
 Approval _____

Contractor _____
 Approval _____
 Contractor's P.O. No. _____
 Representative _____

Material

	792FB, 794FB
Body	Bronze ASTM B62 (85-5-5-5)
Cover	Bronze ASTM B62 (85-5-5-5)
Seats	PTFE
O-Rings	Buna-N

Dimensions and Weights

SIZE		DIMENSIONS								WEIGHT							
	A	B	C	D	E	F	G										
in.	mm	in.	mm	in.	mm	in.	mm	in.	mm	in.	mm	lbs.	kg.				
792FB																	
1	25	6 ⁷ / ₈	175	4 ¹⁵ / ₁₆	125	4 ⁵ / ₈	118	10	254	7 ³ / ₄	197	10 ⁹ / ₁₆	259	3/4	20	35	15.8
1 ¹ / ₄	32	9 ³ / ₈	238	6 ³ / ₄	171	4 ³ / ₈	111	10	254	10 ³ / ₈	264	12 ³ / ₄	324	1 ¹ / ₄	32	65	29.4
1 ¹ / ₂	40	9 ³ / ₈	238	6 ³ / ₄	171	4 ³ / ₈	111	10	254	10 ³ / ₈	264	12 ³ / ₄	324	1 ¹ / ₄	32	65	29.4
2	50	10 ⁵ / ₈	270	8 ³ / ₁₆	208	7 ¹ / ₈	181	20	508	12 ⁵ / ₈	321	16 ³ / ₈	416	1 ¹ / ₂	40	118	53.5
2 ¹ / ₂	65	13 ¹ / ₂	343	12	305	8 ³ / ₁₆	205	20	508	17 ²¹ / ₃₂	448	20 ³ / ₈	518	1 ¹ / ₂	40	249	112.9
3	80	13 ¹ / ₂	343	12	305	8 ³ / ₁₆	205	20	508	17 ²¹ / ₃₂	448	20 ³ / ₈	518	1 ¹ / ₂	40	249	112.9
4††	100	16	406	16 ¹³ / ₁₆	427	15 ¹ / ₂	394	14+	356	23 ¹ / ₂	597	24 ¹ / ₂	622	1 ¹ / ₂	40	435	197.2
5††	125	22	559	18 ⁵ / ₈	473	17 ¹ / ₄	438	14+	356	25 ¹¹ / ₁₆	653	26 ¹ / ₄	667	1 ¹ / ₂	40	746	338.3
6††	150	22	559	18 ⁵ / ₈	473	17 ¹ / ₄	438	14+	356	25 ¹¹ / ₁₆	653	26 ¹ / ₄	667	1 ¹ / ₂	40	746	338.3
794FB																	
1	25	7 ¹ / ₈	181	4 ¹⁵ / ₁₆	125	4 ⁵ / ₈	118	10	254	7 ³ / ₄	197	10 ⁹ / ₁₆	259	3/4	20	40	18.1
1 ¹ / ₄	32	9 ³ / ₈	238	6 ³ / ₄	171	4 ³ / ₈	111	10	254	10 ³ / ₈	264	12 ³ / ₄	324	1 ¹ / ₄	32	70	31.7
1 ¹ / ₂	40	9 ³ / ₈	238	6 ³ / ₄	171	4 ³ / ₈	111	10	254	10 ³ / ₈	264	12 ³ / ₄	324	1 ¹ / ₄	32	70	31.7
2	50	10 ⁵ / ₈	270	8 ³ / ₁₆	208	7 ¹ / ₈	181	20	508	12 ⁵ / ₈	321	16 ³ / ₈	416	1 ¹ / ₂	40	120	54.4
2 ¹ / ₂	65	14 ¹ / ₄	362	12	305	8 ³ / ₁₆	205	20	508	17 ²¹ / ₃₂	448	20 ³ / ₈	518	1 ¹ / ₂	40	260	117.9
3	80	14 ¹ / ₄	362	12	305	8 ³ / ₁₆	205	20	508	17 ²¹ / ₃₂	448	20 ³ / ₈	518	1 ¹ / ₂	40	260	117.9
4††	100	16 ¹ / ₂	419	16 ¹³ / ₁₆	427	15 ¹ / ₂	394	14+	356	23 ¹ / ₂	597	24 ¹ / ₂	622	1 ¹ / ₂	40	450	204.0
5††	125	22 ⁷ / ₈	581	18 ⁵ / ₈	473	17 ¹ / ₄	438	14+	356	25 ¹¹ / ₁₆	653	26 ¹ / ₄	667	1 ¹ / ₂	40	—	—
6††	150	22 ⁷ / ₈	581	18 ⁵ / ₈	473	17 ¹ / ₄	438	14+	356	25 ¹¹ / ₁₆	653	26 ¹ / ₄	667	1 ¹ / ₂	40	—	—

Apply For Certified Drawings.

+ 4", 5" and 6" units are standard with a gear operator. The handwheel dimension is 10".

†† 4", 5" and 6" units are standard with floor supports. Dimension "B" reflects this standard in those sizes.

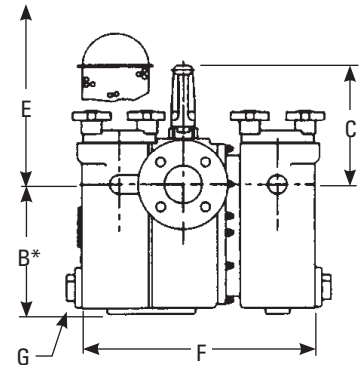

*"B" dimension includes the floor supports when applicable

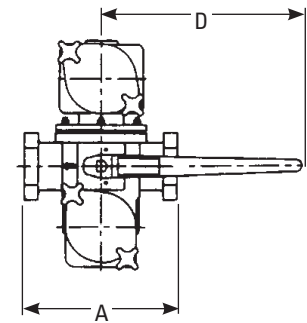

Models 792FB, 794FB

Mueller Steam Specialty product specifications in U.S. customary units and metric are approximate and are provided for reference only. For precise measurements, please contact Mueller Steam Specialty Technical Service. Mueller Steam Specialty reserves the right to change or modify product design, construction, specifications, or materials without prior notice and without incurring any obligation to make such changes and modifications on Mueller Steam Specialty products previously or subsequently sold.



A Watts Water Technologies Company

USA: St. Pauls, NC • Tel. 1-800-334-6259 • Fax 1-800-421-6772 • www.muellersteam.com

ES-MS-792FB_794FB 1020



ISO 9001-2008
CERTIFIED

© 2010 Mueller Steam Specialty