

Model: 791SA

Ball-Plex™ Cast Iron Screwed Ends Duplex Strainers Sizes: 3/4" - 3" (20 - 80mm)

Pressure/Temperature-Non-Shock		
Model	Material	Rating
791SA	Cast	175psi @ -20°F to 150°F
	Iron	12.07 bar @ 65.56°C
		150psi @ 250°F
		10.34 bar @ 121.11°C

*Max. temp. can be limited by gasket and seat material. Consult factory.

791SA

Class 125



Model 791SA

Strainers provide economical protection for costly pumps, meters, valves, and other similar mechanical equipment by straining foreign matter from the connected piping system. Installation of a strainer before mechanical equipment can ensure trouble free service and avoid costly shutdowns for repair or replacement of equipment damaged by foreign matter. The size of the perforation or mesh in the basket screen will determine the smallest particles captured. See Strainer Information section of the Mueller Steam Specialty Engineering binder for detailed information including sizes and materials available.

Typical Service

- Duplex Strainers are designed for use in fluid handling systems where the flow cannot be shut down for basket cleaning.
- Typical services include cooling water, compressors, condensers, fire lines, fuel lines, lubrication systems, salt and fresh water systems, chemical process systems, pump suction service, and more.
- Consider strainer body and screen material as well as gasket and seat materials for suitability for particular service.

Features

- Ball-Plex™ Duplex Strainers use 3-way balls as the diverter valves
- Balls are 316SS for corrosion resistance, strength, and resistance to build-up of solids on the balls' surfaces.
- PTFE seats provide bubble-tight sealing, superior to metal seats in other designs. This eliminates potentially dangerous leakage into the chamber being cleaned.
- Two part body casting allows true and easy in-line service
- After removal of the cover and basket, all working parts are easily accessible even with the unit in line.
- The handle covers the pressurized chamber. This prevents accidental opening of the pressurized chamber, and allows easy access to the chamber to be cleaned.

Baskets

- Large open area ratios ensure minimum pressure drop across the unit.
- See Pressure Drop Charts in Technical Data section of the Mueller Steam Specialty Engineering Binder.

MODEL	SIZES	STANDARD (WATER)	
		MATERIAL	OPENING
791SA	3/4" - 3"	304SS	.062 perf

Job Name _____
 Job Location _____
 Engineer _____
 Approval _____

Contractor _____
 Approval _____
 Contractor's P.O. No. _____
 Representative _____

Material

791FA	
Body	Cast Iron ASTM A126-B
Cover	Cast Iron ASTM A126-B
Seats	PTFE
O-Rings	Buna-N

Dimensions and Weights

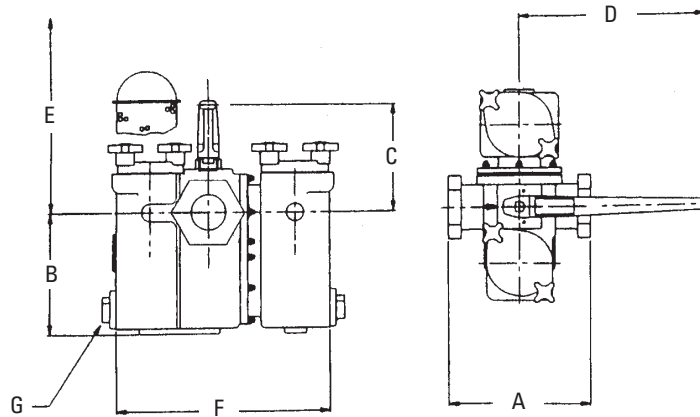

Model 791SA

SIZE		DIMENSIONS										WEIGHT					
		A		B		C		D		E Screen Removal		F		G (NPT)			
in.	mm	in.	mm	in.	mm	in.	mm	in.	mm	in.	mm	in.	mm	in.	mm	lbs.	kgs.
3/4"	20	5 1/2	140	4 15/16	125	4 5/8	118	10	254	7 3/4	197	10 3/16	259	3/4	20	30	13.6
1"	25	5 1/2	140	4 15/16	125	4 5/8	118	10	254	7 3/4	197	10 3/16	259	3/4	32	30	13.6
1 1/4"	32	7 1/2	191	6 3/4	171	4 3/8	111.1	10	254	10 3/8	264	12 3/4	324	1 1/4	32	53	24
1 1/2"	40	7 1/2	191	6 3/4	171	4 3/8	111.1	10	254	10 3/8	264	12 3/4	324	1 1/4	32	54	24
2"	50	10	254	8 3/16	208	7 1/8	181	20	508	12 5/8	321	16 3/8	416	1 1/4	40	105	47
2 1/2"	65	11 1/2	292	12	309	8 1/16	205	20	508	17 11/16	449	20 3/8	518	1 1/2	40	195	88
3"	80	11 1/2	292	12	309	8 1/16	205	20	508	17 11/16	449	20 3/8	518	1 1/2	40	200	90

Apply For Certified Drawings.

Mueller Steam Specialty product specifications in U.S. customary units and metric are approximate and are provided for reference only. For precise measurements, please contact Mueller Steam Specialty Technical Service. Mueller Steam Specialty reserves the right to change or modify product design, construction, specifications, or materials without prior notice and without incurring any obligation to make such changes and modifications on Mueller Steam Specialty products previously or subsequently sold.

