

Models: 782-SS, 782-SS-WE*

Cast Stainless Steel Flanged & Butt Weld End Y Strainers

Sizes: 1/2" - 24" (15-600mm)

Pressure / Temperature - Non-Shock

Model	Material	Rating
782-SS	Stainless	720psi @ -20°F to 100°F
782-WE-SS	Steel	49.64 bar @ 37.78°C 420psi @ 850°F 28.96 bar @ 454.44°C

782SS
782SSWE

Class 300
Class 300



Model 782-SS



Model 782-SS-WE

Typical Service

- Used extensively to strain foreign matter from pipelines and provide economical protection for costly pumps, meters, valves, and other similar mechanical equipment.
- Especially important where weld debris is likely present in the pipeline.
- Well suited for long service in high pressure and temperature applications.

Features

- Machined seats in both body and cap align and lock the screen in place to stop sediment bypass.
- Machined seats facilitate alignment and accurate reseating after servicing.

Construction

- Designed for Class 300 specifications.
- Heavy gauge reinforced screens are used.

IMPORTANT NOTE: Model 782-SS-WE ends are machined to match Schedule 40 pipe. Other connections are available, consult factory. Model 782-SS flanges are raised face flanges

Self-Cleaning

- Self-cleaning is accomplished by opening the plug or valve connected to the blowoff outlet.

Blowoff Outlets

- Blowoff outlets are NPT tapped at location C. See next page for NPT sizes.
- Blind covers are available, consult factory.

Capacity

- Generously proportioned bodies.
- Open Area Ratio much greater than pipe size, ensuring low pressure drop.
- Minimum of 4 to 1 Open Area Ratio.

Screens

MODEL	SIZES	STANDARD (WATER)		STEAM RECOMENDATION	
		MATERIAL	OPENING	MATERIAL	OPENING
All	1/2" - 4"	304SS	.062 perf	304SS	.033 perf
	5" - 10"	304SS	.125 perf	304SS	.062 perf

Material

782-SS, 782-SS-WE	
Body	Carbon Steel, ASTM A216 Grade WCB
Cap	Carbon Steel, ASTM A216 Grade WCB
Gasket	316SS Tang Graphite

*782/782-WE supersede model 762/762-WE.
762/762-WE still available upon request

Job Name _____

Contractor _____

Job Location _____

Approval _____

Engineer _____

Contractor's P.O. No. _____

Approval _____

Representative _____

Pressure Drop

See Pressure Drop Charts in Technical Data Section of the Mueller Steam Specialty Engineering binder.

Dimensions and Weights

SIZE		DIMENSIONS								WEIGHT	
		A		B		C (NPT)		D Screen Removal			
in.	mm	in.	mm	in.	mm	in.	mm	in.	mm	lbs.	kgs.
782-SS											
1/2	15	5 7/8	149	3 1/2	89	3/8	10	5	130	5.5	2.5
3/4	20	7 7/8	187	3 3/4	95	1/2	15	5	130	12.3	5.5
1	25	7 7/8	187	3 3/4	95	1/2	15	5	130	13	5.9
1 1/4	32	7	178	4 3/4	121	1/2	15	8	203	18.3	8.2
1 1/2	40	7 1/8	181	4 3/4	121	1/2	15	8	203	18	8.1
2	50	8 5/8	219	5 1/4	133	1/2	15	7	178	22	10
2 1/2	65	10 5/8	269	6 1/2	165	1	25	9 3/4	248	32	14.5
3	80	12	305	7	178	1	25	10	254	49	22
4	100	14 1/2	368	8 1/4	210	1 1/2	40	12	305	90	40
5	125	19 5/16	491	13 1/2	343	2	50	20	508	120	54.5
6	150	19 5/16	491	13 1/2	343	2	50	20	508	175	79
8	200	23 3/8	594	15 3/4	400	2	50	22 3/4	578	300	136
10	250	27 3/8	695	18 1/2	470	2	50	28	711	440	200
12	300	32	813	22 1/4	565	2	50	30	762	650	295
14	350	36	914	25	635	2	50	36 1/2	927	1365	619
16	400	41 1/16	1056	26 1/2	673	2	50	42	1067	1936	878
18	450	46	1168	34 7/8	886	2	50	50 7/8	1292	2576	1168
20	500	49 1/2	1257	39	991	2	50	55 3/8	1407	3111	1411
24	600	58 3/8	1483	44 1/16	1119	2	50	67 1/4	1708	5305	2406
782-SS-WE											
1/2	15	6 5/8	168	3 1/2	89	3/8	10	5	130	3	1.3
3/4	20	8 5/16	211	3 3/4	95	1/2	15	5	130	9	4
1	25	8 5/16	211	3 3/4	95	1/2	15	5	130	9	4
1 1/4	32	10 5/8	260	5 1/4	133	1/2	15	8	203	12	5.4
1 1/2	40	10 3/4	279	5 1/4	133	1/2	15	8	203	13	5.9
2	50	8 5/8	219	5 1/4	133	1/2	15	7	178	10	4.5
2 1/2	65	10 5/8	269	6 1/2	165	1	25	9 3/4	248	14	6.3
3	80	12	305	7	178	1	25	10	254	20	9
4	100	14 1/2	368	8 1/4	210	1 1/2	40	12	305	40	18
5	125	16 3/8	416	11 1/4	286	2	50	20	508	80	36
6	150	19 5/16	491	13 1/2	343	2	50	20	508	90	40
8	200	23 3/8	594	15 3/4	400	2	50	22 3/4	578	168	76
10	250	27 3/8	695	18 1/2	470	2	50	28	711	250	113
12	300	32	813	22 1/4	565	2	50	30	762	440	200
14	350	36	914	25	635	2	50	36 1/2	927	1033	468
16	400	41 3/4	1060	26 1/2	673	2	50	42	1067	1520	639
18	450	46	1168	34 7/8	886	2	50	50 7/8	1292	2060	934
20	500	49 1/2	1257	39	991	2	50	55 3/8	1407	2471	1120
24	600	58 1/2	1486	44 1/16	1119	2	50	67 1/4	1708	4500	2040

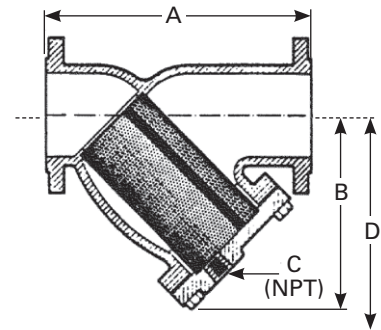

Model 782-SS

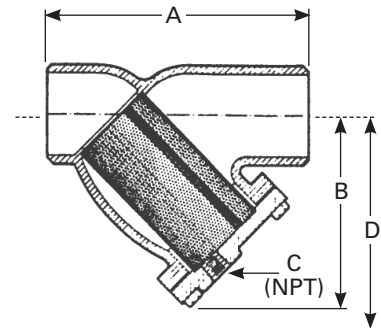

Model 782-SS-WE

Mueller Steam Specialty product specifications in U.S. customary units and metric are approximate and are provided for reference only. For precise measurements, please contact Mueller Steam Specialty Technical Service. Mueller Steam Specialty reserves the right to change or modify product design, construction, specifications, or materials without prior notice and without incurring any obligation to make such changes and modifications on Mueller Steam Specialty products previously or subsequently sold.



A Watts Water Technologies Company

USA: St. Pauls, NC • Tel. 1-800-334-6259 • Fax 1-800-421-6772 • www.muellersteam.com

ES-MS-782SS_782SSWE 1020



ISO 9001-2008
CERTIFIED

© 2010 Mueller Steam Specialty