

Models: 764, 765M*, 766M*, 767

Cast Carbon & Alloy Steel Flanged Ends Y Strainers

Sizes: 1/2" - 12" (15 - 300mm)

Pressure / Temperature - Non-Shock		
Model	Material	Rating
764	Carbon Steel	1480psi @ -20°F to 406°F
		102.04 bar @ 37.78°C
		640psi @ 850°F
		44.13 bar @ 454.44°C
765M	Carbon Steel	2220psi @ -20°F to 100°F
		153.06 bar @ 37.78°C
		955psi @ 850°F
		65.84 bar @ 454.44°C
766M	Carbon Steel	3705psi @ -20°F to 100°F
		255.45 bar @ 37.78°C
		1595psi @ 850°F
		109.97 bar @ 454.44°C
767	Carbon Steel	6170psi @ -20°F to 100°F
		425.41 bar @ 37.78°C
		2655psi @ 850°F
		183.06 bar @ 454.44°C
764	Chrome-Moly	1500psi @ -20°F to 100°F
		103.42 bar @ 37.78°C
		600psi @ 975°F
		41.37 bar @ 523.89°C
765M	Chrome-Moly	2250psi @ -20°F to 100°F
		155.13 bar @ 37.78°C
		900psi @ 975°F
		62.05 bar @ 523.89°C
766M	Chrome-Moly	3750psi @ -20°F to 100°F
		258.55 bar @ 37.78°C
		1500psi @ 975°F
		103.42 bar @ 523.89°C
767	Chrome-Moly	6250psi @ -20°F to 100°F
		430.92 bar @ 37.78°C
		2500psi @ 838°F
		172.37 bar @ 523.89°C

764
765M
766M
767

Class 600
Class 900
Class 1500
Class 2500



Models: 764, 765M, 766M, 767

* 765M and 766M supersede models 765/766. Consult factory.

Typical Service

- Used extensively to strain foreign matter from pipelines and provide economical protection for costly pumps, meters, valves, and other similar mechanical equipment.
- These are especially critical as weld debris is often present in the pipeline.
- Well suited for long service in high pressure and temperature applications.

Features

- Machined seats in both body and cap align and lock the screen in place to stop sediment bypass.
- Machined seats facilitate alignment and accurate reseating after servicing.

Construction

- Designed for high pressure and temperature services.
- Alloy bolting for all sizes.
- Heavy gauge reinforced screens are used.
- Flanged are back faced, or spot faced at the boltholes.
- Ring Type Joint (RTJ) flanges are available, consult factory.

Self-Cleaning

- Self-cleaning is accomplished by opening the plug or valve connected to the blowoff outlet, if provided.
- Cleaning usually accomplished by shutting off line pressure and disassembling strainer.

Blowoff Outlets

- Cover flange for 764 is furnished with blowoff tapping, not plugged.
- All other covers normally furnished as blind flanges. Socket weld blowoff connection available, specify on order.

Capacity

- Generously proportioned bodies.
- Open Area Ratio much greater than pipe size, ensuring low pressure drop.
- Minimum of 4 to 1 Open Area Ratio.

Screens

MODEL	SIZES	STANDARD (WATER)		STEAM RECOMENDATION	
		MATERIAL	OPENING	MATERIAL	OPENING
All	1/2 - 4"	304SS	.062 perf	304SS	.033 perf
All	5" and Up	304SS	.125 perf	304SS	.045 perf

Job Name _____

Contractor _____

Job Location _____

Approval _____

Engineer _____

Contractor's P.O. No. _____

Approval _____

Representative _____

Materials

	764, 765M, 766M, 767
Body	Carbon Steel, ASTM A216 Grade WCB
Cover	Carbon Steel, ASTM A216 Grade WCB
Gasket	Spiral Wound SS, Graphite Filled

ALSO AVAILABLE:

Body/Cap: Carbon-Moly ASTM A217 Gr. W1,
 Chrome-Moly ASTM A217 Gr. WC6,
 Chrome-Moly ASTM A217 Gr. WC9

Pressure Drop

See Pressure Drop Charts in Technical Data Section in the Mueller Steam Specialty Engineering binder.

Dimensions and Weights

SIZE		DIMENSIONS						WEIGHT			
		A		B		C		D Screen Removal			
in.	mm	in.	mm	in.	mm	in.	mm	in.	mm	in.	mm
764											
1/2	15	6 5/8	168	3 1/2	89	3/8	10	5	130	6	2.7
3/4	20	8 5/16	211	3 3/4	95	1/2	15	5	130	12.3	5.5
1	25	8 5/16	211	3 3/4	95	1/2	15	5	130	12.3	5.5
1 1/4	32	10 1/8	257	5 1/2	140	1/2	15	8	203	19	8.6
1 1/2	40	10 1/4	260	5 1/2	140	1/2	15	8	203	27	12
2	50	11	279	7	178	1/2	15	10	254	40	18
2 1/2	65	12	305	8 1/4	210	1	25	12 1/2	318	60	27
3	80	13 1/2	343	9 1/4	235	1 1/4	32	14 1/2	368	78	35
4	100	17 5/16	456	12 1/2	318	1 1/2	40	19 1/2	495	160	72.7
5	125	22 1/4	565	15	381	2	50	23	584	254	115
6	150	22 5/8	651	20	508	2	50	31	787	364	165
8	200	31 3/4	806	24	610	2	50	38 1/2	978	670	304
10	250	37 11/16	957	28 1/2	724	2	50	45 1/2	1156	1090	495
12	300	45 1/2	1156	34 1/2	876	2	50	52	1321	1558	708

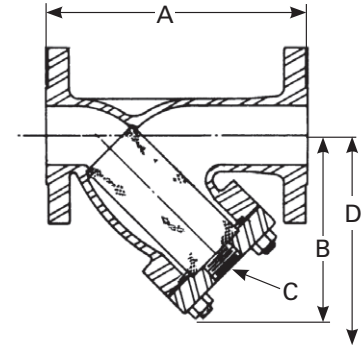

Model 764

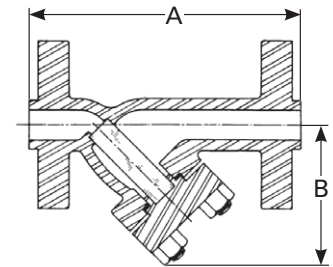

Models 765M, 766M, 767

SIZE		DIMENSIONS				WEIGHT	
		A		B			
in.	mm	in.	mm	in.	mm	lbs.	kgs.
765M							
1/2	15	8 1/8	206	4 1/4	108	20	9
3/4	20	9 1/16	230	4 3/4	121	30	13.6
1	25	10 11/16	271	5 3/4	146	52	23
1 1/4	32	12	305	6 3/4	171	64.5	29
1 1/2	40	12	305	6 3/4	171	64.5	29
2	50	13 5/16	354	7 1/2	191	93	42
2 1/2	65	17 1/2	445	10 3/4	273	185	84
3	80	17 1/2	445	10 3/4	273	185	84
4	100	23 3/4	591	15	381	250	113
6	150	27 3/4	705	18 7/8	479	560	254
8	200	33 1/4	846	23 3/8	606	1000	454
10	250	CF	CF	CF	CF	CF	CF
12	300	CF	CF	CF	CF	CF	CF

SIZE		DIMENSIONS				WEIGHT	
		A		B			
in.	mm	in.	mm	in.	mm	lbs.	kgs.
766M							
1/2	15	8 1/8	206	4 1/4	108	20	9
3/4	20	9 1/16	230	4 3/4	121	30	13.6
1	25	10 11/16	271	5 3/4	146	52	23
1 1/4	32	12	305	6 3/4	171	64.5	29
1 1/2	40	12	305	6 3/4	171	64.5	29
2	50	13 5/16	354	7 1/2	191	93	42
2 1/2	65	17 1/2	445	10 3/4	273	185	84
3	80	17 1/2	445	10 3/4	273	185	84
4	100	23 3/4	591	15	381	334	151
6	150	30 5/8	778	20 1/2	521	770	350
8	200	39	991	26 15/16	684	1200	545
10	250	CF	CF	CF	CF	CF	CF
12	300	CF	CF	CF	CF	CF	CF

SIZE		DIMENSIONS				WEIGHT	
		A		B			
in.	mm	in.	mm	in.	mm	lbs.	kgs.
767							
1/2	15	12 5/8	321	7 11/16	195	30	13.6
3/4	20	12 5/8	321	7 11/16	195	40	18
1	25	12 5/8	321	7 11/16	195	65	29.5
1 1/4	32	16 7/8	429	10 1/2	267	140	63.3
1 1/2	40	16 7/8	429	10 1/2	267	140	63.6
2	50	18 5/16	481	12 1/2	318	240	109
2 1/2	65	25 3/4	654	18 3/16	478	500	227
3	80	26 3/4	679	18 3/16	478	560	254
4	100	33 3/8	854	20 1/4	514	850	386
6	150	33 3/4	857	20	508	900	862
8	200	CF	CF	CF	CF	CF	CF
10	250	CF	CF	CF	CF	CF	CF
12	300	CF	CF	CF	CF	CF	CF

Apply For Certified Drawings.
 CF= Consult Factory

Mueller Steam Specialty product specifications in U.S. customary units and metric are approximate and are provided for reference only. For precise measurements, please contact Mueller Steam Specialty Technical Service. Mueller Steam Specialty reserves the right to change or modify product design, construction, specifications, or materials without prior notice and without incurring any obligation to make such changes and modifications on Mueller Steam Specialty products previously or subsequently sold.



A Watts Water Technologies Company

ES-MS-764_765M_766M_767 1020

USA: St. Pauls, NC • Tel. 1-800-334-6259 • Fax 1-800-421-6772 • www.muellersteam.com



© 2010 Mueller Steam Specialty